

GENERAC®

Owner's Manual
For
Automatic Transfer Switch

400 Amp, Service Entrance

Model Number
RXSW400A3CUL

MODEL NUMBER: _____

SERIAL NUMBER: _____

DATE PURCHASED: _____

Register your Generac product at:

WWW.GENERAC.COM

1-888-GENERAC
(888-436-3722)



Para español, visita: <http://www.generac.com/service-support/product-support-lookup>

Pour le français, visiter : <http://www.generac.com/service-support/product-support-lookup>

SAVE THIS MANUAL FOR FUTURE REFERENCE

 **WARNING**

CANCER AND REPRODUCTIVE HARM

www.P65Warnings.ca.gov

(000393a)

Table of Contents

Section 1: Introduction and Safety

Introduction	1
Read This Manual Thoroughly	1
Safety Rules	1
Electrical Hazards	2
General Hazards	3

Section 2: General Information

Unpacking	5
Contents in Loose Parts Bag	5
Equipment Description	5
Transfer Switch Mechanism	5
Utility Service Circuit Breaker	6
Transfer Switch Data Decal	6
Transfer Switch Enclosure	6
Safe Use of Transfer Switch	6
Load Management Options	6
Smart A/C Module (SACM)	6
Smart Management Module (SMM)	7
Application Considerations	7

Section 3: Installation

Introduction to Installation	9
Mounting	9
Open Enclosure	9
Connecting Power Source and Generator Power Supply	10
Connecting Start Circuit Wires	11
Connecting SACM	11
Control of Air Conditioner Load	11
Auxiliary Contacts	13
Fault Current Label	13

Section 4: Operation

Functional Tests and Adjustments	15
Manual Operation	15
Close to Normal Source Side	16
Close to Standby Source Side	16
Return to Normal Source Side	16
Voltage Checks	16
Utility Voltage Checks	16
Generator Voltage Checks	16

Generator Tests Under Load	17
Checking Automatic Operation	17
Installation Summary	17
Shutting Generator Down While Under Load	18
Shutting Generator Down To Perform Maintenance	18
Testing The SACM	18
SACM Fuse Service	18
Testing The SMM	18

Section 5: Drawings and Diagrams

Installation Drawing—400A Service Entrance Rated	19
Interconnection Drawing—Liquid Cooled Generator	20
Interconnection Drawing—Liquid Cooled Generator	21
Schematic Diagram	22
Wiring Diagram	23

This page intentionally left blank.

Section 1: Introduction and Safety

Introduction

Thank you for purchasing a Generac Power Systems Inc. product. This unit has been designed to provide high performance, efficient operation, and years of use when maintained properly.

Read This Manual Thoroughly



WARNING

Consult Manual. Read and understand manual completely before using product. Failure to completely understand manual and product could result in death or serious injury. (000100a)

If any section of this manual is not understood, contact the nearest Independent Authorized Service Dealer (IASD) or Generac Customer Service at 1-888-436-3722 (1-888-GENERAC), or visit www.generac.com for starting, operating, and servicing procedures. The owner is responsible for proper maintenance and safe use of the unit.

SAVE THESE INSTRUCTIONS for future reference. This manual contains important instructions that must be followed during placement, operation, and maintenance of the unit and its components. Always supply this manual to any individual that will use this unit, and instruct them on how to correctly start, operate, and stop the unit in case of emergency.

Safety Rules

The manufacturer cannot anticipate every possible circumstance that might involve a hazard. The alerts in this manual, and on tags and decals affixed to the unit, are not all inclusive. If using a procedure, work method, or operating technique that the manufacturer does not specifically recommend, verify that it is safe for others and does not render the equipment unsafe.

Throughout this publication, and on tags and decals affixed to the unit, DANGER, WARNING, CAUTION, and NOTE blocks are used to alert personnel to special instructions about a particular operation that may be hazardous if performed incorrectly or carelessly. Observe them carefully. Alert definitions are as follows:

DANGER

Indicates a hazardous situation which, if not avoided, will result in death or serious injury.

(000001)

WARNING

Indicates a hazardous situation which, if not avoided, could result in death or serious injury.

(000002)

CAUTION

Indicates a hazardous situation which, if not avoided, could result in minor or moderate injury.

(000003)

NOTE: Notes contain additional information important to a procedure and will be found within the regular text of this manual.

These safety alerts cannot eliminate the hazards that they indicate. Common sense and strict compliance with the special instructions while performing the action or service are essential to preventing accidents.

Electrical Hazards



⚠ DANGER

Electrocution. High voltage is present at transfer switch and terminals. Contact with live terminals will result in death or serious injury.

(000129)



⚠ DANGER

Electrocution. Water contact with a power source, if not avoided, will result in death or serious injury.

(000104)



⚠ DANGER

Electrocution. In the event of electrical accident, immediately shut power OFF. Use non-conductive implements to free victim from live conductor. Apply first aid and get medical help. Failure to do so will result in death or serious injury.

(000145)

⚠ DANGER

Electrical backfeed. Use only approved switchgear to isolate generator from the normal power source. Failure to do so will result in death, serious injury, and equipment damage.

(000237)



⚠ DANGER

Electrocution, equipment and property damage. Handle transfer switches carefully when installing. Never install a damaged transfer switch. Doing so could result in death or serious injury, equipment and property damage.

(000195)



⚠ DANGER

Electrocution. Turn utility supply OFF before working on utility connections of the transfer switch. Failure to do so will result in death or serious injury.

(000123)



⚠ DANGER

Electrocution. Do not disable or modify the connection box door safety switch. Doing so will result in death or serious injury.

(000157)

⚠ DANGER

Automatic start-up. Disconnect utility power and render unit inoperable before working on unit. Failure to do so will result in death or serious injury.

(000191)

⚠ DANGER

Equipment malfunction. Installing a dirty or damaged transfer switch will cause equipment malfunction and will result in death or serious injury.

(000119)

⚠ WARNING

Electric shock. Only a trained and licensed electrician should perform wiring and connections to unit. Failure to follow proper installation requirements could result in death, serious injury, and equipment or property damage.

(000155a)

⚠ CAUTION

Equipment damage. Verify all conductors are tightened to the factory specified torque value. Failure to do so could result in damage to the switch base.

(000120)

⚠ CAUTION

Equipment damage. Perform functional tests in the exact order they are presented in the manual. Failure to do so could result in equipment damage.

(000121)

⚠ CAUTION

Equipment damage. Exceeding rated voltage and current will damage the auxiliary contacts. Verify that voltage and current are within specification before energizing this equipment.

(000134a)

General Hazards

DANGER

Electrical backfeed. Use only approved switchgear to isolate generator from the normal power source. Failure to do so will result in death, serious injury, and equipment damage.

(000237)



DANGER

Electrocution. High voltage is present at transfer switch and terminals. Contact with live terminals will result in death or serious injury.

(000129)



DANGER

Electrocution. Turn utility supply OFF before working on utility connections of the transfer switch. Failure to do so will result in death or serious injury.

(000123)



DANGER

Electrocution. Water contact with a power source, if not avoided, will result in death or serious injury.

(000104)



DANGER

Electrocution. Do not wear jewelry while working on this equipment. Doing so will result in death or serious injury.

(000188)



DANGER

Electrocution. Only authorized personnel should access transfer switch interior. Transfer switch doors should be kept closed and locked. Failure to do so will result in death or serious injury.

(000213)

DANGER

Automatic start-up. Disconnect utility power and render unit inoperable before working on unit. Failure to do so will result in death or serious injury.

(000191)



DANGER

Electrocution. In the event of electrical accident, immediately shut power OFF. Use non-conductive implements to free victim from live conductor. Apply first aid and get medical help. Failure to do so will result in death or serious injury.

(000145)



WARNING

Loss of life. This product is not intended to be used in a critical life support application. Failure to adhere to this warning could result in death or serious injury.

(000209b)

WARNING

Equipment damage. This unit is not intended for use as a prime power source. It is intended for use as an intermediate power supply in the event of temporary power outage only. Doing so could result in death, serious injury, and equipment damage.

(000247a)

WARNING

Risk of injury. Do not operate or service this machine if not fully alert. Fatigue can impair the ability to operate or service this equipment and could result in death or serious injury.

(000215a)

- Competent, qualified personnel should install, operate and service this equipment. Adhere strictly to local, state and national electrical and building codes. When using this equipment, comply with regulations established by the National Electrical Code (NEC), CSA Standard; C22.1 Canadian Electric Code, the Occupational Safety and Health Administration (OSHA), or the local agency for workplace health and safety.
- If working on this equipment while standing on metal or concrete, place insulative mats over a dry wood platform. Work on this equipment only while standing on such insulative mats.
- Never work on this equipment while physically or mentally fatigued.
- Any voltage measurements should be performed with a meter that meets UL3111 safety standards, and meets or exceeds overvoltage class CAT III.

This page intentionally left blank.

Section 2: General Information

Unpacking

Carefully unpack the transfer switch. Inspect closely for any damage that might have occurred during shipment. The purchaser must file with the carrier any claims for loss or damage incurred while in transit. Verify that all parts are included.

Verify that all packing material is completely removed from the switch prior to installation.

Contents in Loose Parts Bag

- Owner's manual
- Warranty statement
- Manual operating handle
- Storage bracket for manual operating handle
- Fault current label
- Clear decal for fault current label

Equipment Description

The automatic transfer switch is used for transferring electrical load from a utility (normal) power source to a generator (standby) power source. Such a transfer of electrical loads occurs automatically when the utility power source has failed or is substantially reduced and the generator source voltage and frequency have reached an acceptable level. The transfer switch prevents electrical feedback between two different power sources (such as the utility and generator sources) and, for that reason, codes require it in all standby electric system installations.

The transfer switch consists of a transfer mechanism, utility service disconnect circuit breaker (if equipped), a control relay, a Smart A/C module, fuses, terminal strip, and fuse holder for connection of sensing wires.

This ETL listed transfer switch has locking provisions for the utility entry cabinet. In addition, it has a lockout/tagout provision for the service entrance circuit breaker.

Transfer Switch Mechanism

See [Figure 2-1](#). These switches are used with a single-phase system, when the single-phase neutral line is to be connected to a neutral lug and is not to be switched.

Solderless, screw-type terminal lugs are standard.

The conductor size range is as follows:

Switch Rating	Wire Range	Conductor Torque Specification
400A	(1) #4-600 MCM (Cu/Al) or (2) 1/0-250 MCM (Cu/Al)	375 in-lbs (42.4 Nm)

This transfer switch is suitable for control of motors, electric discharge lamps, tungsten filament and electric heating equipment where the sum of motor full load ampere ratings and the ampere ratings of other loads do not exceed the ampere rating of the switch and the tungsten load does not exceed 30% of the switch rating.

This ETL listed transfer switch is for use in optional standby systems only (NEC article 702).

This transfer switch is suitable for use on a circuit capable of 22,000 rms symmetrical amperes, 240 VAC maximum.

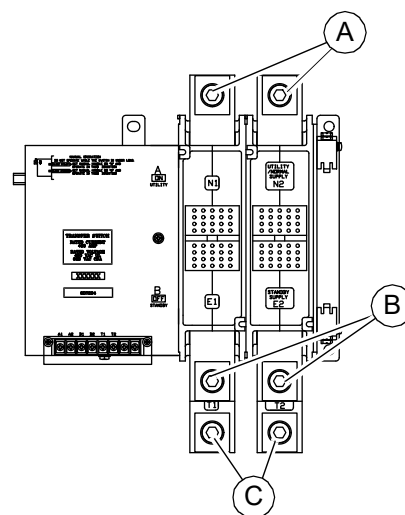

000218

Figure 2-1. Typical Single-Phase ATS Transfer Mechanism

A	Utility Lugs (N1 & N2)
B	Generator Lugs (E1 & E2)
C	Load Lugs (T1 & T2)

Utility Service Circuit Breaker

The utility service circuit breaker is:

Generac, 400AF

- 120/240VAC, 400A
- 50/60 Hertz
- Wire range: (1) #4-600 MCM or (2) 1/0-250 MCM (Cu/Al)
- See Circuit Breaker markings and decal on inside of the door for torque specifications.

Transfer Switch Data Decal

See [Figure 2-2](#). A data decal is permanently affixed to the transfer switch enclosure. Use this transfer switch only with the specific limits shown on the data decal and on other decals and labels that may be affixed to the switch. This will prevent damage to equipment and property.

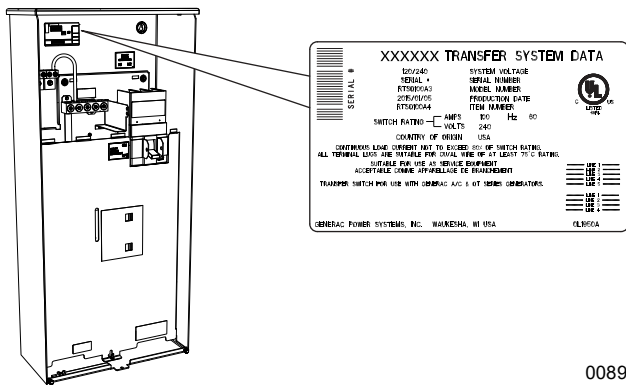

Figure 2-2. Data Decal Location

When requesting information or ordering parts for this equipment, make sure to include all information from the data decal.

For future reference, record the serial number in the space provided on the front cover of this manual.

Transfer Switch Enclosure

The standard switch enclosure is a National Electrical Manufacturer's Association (NEMA) 3R type. NEMA 3R (indoor/outdoor rated) type enclosures primarily provide a degree of protection against falling rain and sleet; are undamaged by the formation of ice on the enclosure.

Safe Use of Transfer Switch



WARNING

Consult Manual. Read and understand manual completely before using product. Failure to completely understand manual and product could result in death or serious injury. (000100a)

Before installing, operating or servicing this equipment, read the [Safety Rules](#) carefully. Comply strictly with all [Safety Rules](#) to prevent accidents and/or damage to the equipment. The manufacturer recommends that a copy of the [Safety Rules](#) be posted near the transfer switch. Also, be sure to read all instructions and information found on tags, labels and decals affixed to the equipment.

The following publications outline the safe use of transfer switches:

- Canadian Electrical Code CE; CSA C22.1
- NFPA 70E: Standard for Electrical Safety In The Workplace
- UL/CUL 1008: Standard for Safety—Automatic Transfer Switches

NOTE: It is essential to use the latest version of any standard to ensure correct and current information.

Load Management Options

Load management systems are designed to work together to prevent a generator from being overloaded by large appliance loads. A Smart A/C Module (SACM) is standard in these switches. An optional Smart Management Module (SMM) is also available.

Smart A/C Module (SACM)

Up to four air conditioner loads can be managed by the SACM. The SACM manages the loads by “shedding” the connected loads in the event of a drop in generator frequency (overload). Loads to be “shed” are in four priority levels on the module.

See [Figure 2-3](#). Priorities A/C 1-4 (A) have connections for an air conditioner. To control an air conditioner, no additional equipment is required. Internal normally closed relays interrupt the 24 VAC thermostat control signal to disable the air conditioner load.

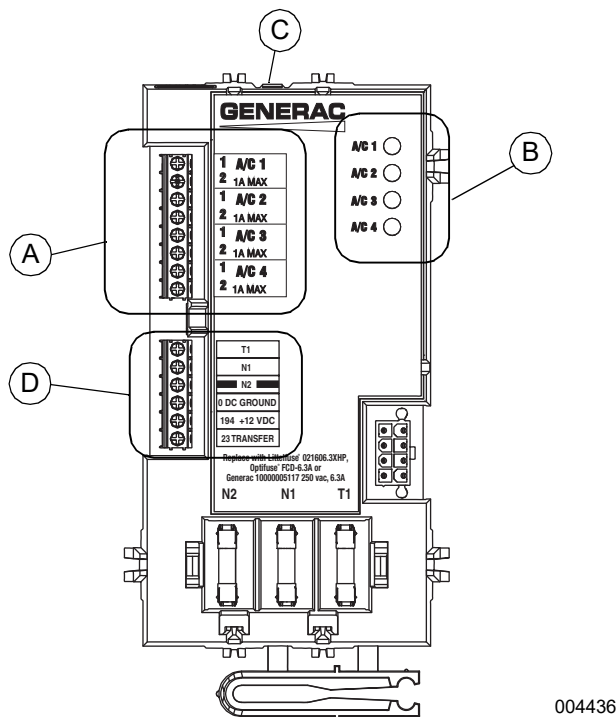

Figure 2-3. Smart A/C Module (SACM)

Table 2-1. Customer Wiring Connections

Terminal Numbering Decal	Wire Numbers
BLUE NO. 3 *	T1 - Fused 120-240 VAC for battery charger
YELLOW NO. 1 & NO. 2	N1 & N2 - Fused 240 VAC - Sensing for utility dropout and pickup
BLACK NO.1 **	0 - DC (-) Common ground wire
RED NO. 2	194 - DC (+) 12 VDC for transfer controls
WHITE NO. 3	23 - Transfer control signal wire

* Must be connected to keep battery charged whether unit is running or not.
 ** Required if generator is paired with Generac Smart Power management transfer switch.

Four LEDs, located on the SACM (B), illuminate when a load is connected and powered.

The SACM has a test button (C) that is used to simulate an overload condition. This button operates even when the transfer signal is inactive. The generator control wiring is connected to terminals (D).

Smart Management Module (SMM) (Sold Separately)

See Figure 2-4. Any loads, including central air conditioners, can be managed using an optional Smart Management Module (SMM). The system can accommodate up to eight individual SMMs.

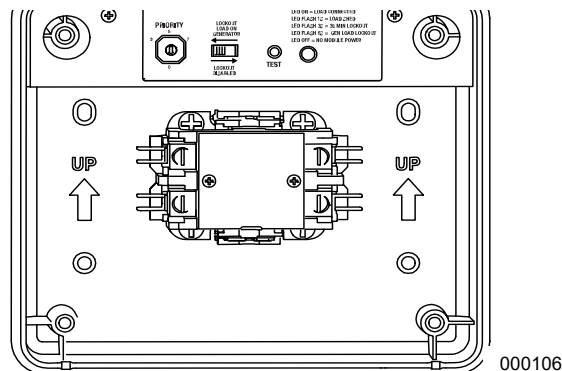

Figure 2-4. Smart Management Module (SMM)

NOTE: SMMs are self-contained and have individual built-in controllers.

Application Considerations

Generator overload condition is determined by generator frequency. Loads are shed when frequency is less than 58 Hz for three seconds or less than 50 Hz for 1/2 second (for 60 Hz systems).

The SACM can be used in conjunction with individual SMMs to manage a combined total of eight loads.

- Use Priorities A/C 1-4 on the SACM as the top priorities, then up to four SMMs as Priorities 5-8.
- Use only select A/C priorities on the SACM as the top priorities, then use additional SMMs as the remaining priorities.
- A SMM can share a priority with an A/C priority on the SACM provided the generator is sized to handle the combined surge load from both appliances. Sharing priorities can allow up to 12 loads to be managed in a properly sized system.

In any combination of modules, the recovery times after a loss of utility power or shutdown due to overload are shown in **Priority Settings**.

Priority Settings

Priority	Recovery Time	SACM	SMM
1	5 minutes	Yes	Yes
2	5 minutes 15 seconds	Yes	Yes
3	5 minutes 30 seconds	Yes	Yes
4	5 minutes 45 seconds	Yes	Yes
5	6 minutes	NA	Yes
6	6 minutes 15 seconds	NA	Yes
7	6 minutes 30 seconds	NA	Yes
8	6 minutes 45 seconds	NA	Yes

Refer to the SMM Owner’s/Installation Manual for detailed characteristics and specifications of that product.

This page intentionally left blank.

Section 3: Installation

Introduction to Installation

This equipment has been wired and tested at the factory. Installing the switch includes the following procedures:

- Mounting the enclosure.
- Connecting power source and load leads.
- Connecting the generator start and sensing circuit.
- Connecting any auxiliary contact (if needed).
- Testing functions.

Mounting

⚠ DANGER

Equipment malfunction. Installing a dirty or damaged transfer switch will cause equipment malfunction and will result in death or serious injury.

(000119)

Mounting dimensions for the transfer switch enclosure are in this manual. Enclosures are typically wall-mounted. See [Drawings and Diagrams](#).

This transfer switch is mounted in a NEMA 3R enclosure. It can be mounted outside or inside and should be based on the layout of installation, convenience, and proximity to the utility supply and load center.

Install the transfer switch as close as possible to the electrical loads that are to be connected to it. Mount the switch vertically to a rigid supporting structure. To prevent switch distortion, level all mounting points. If necessary, use washers behind mounting holes to level the unit.

Open Enclosure

See [Figure 3-1](#). First, remove outer cover (A):

1. Remove two thumb screws (B).
2. Slide slot (C) over retention tab.
3. Lower outer cover until clear of top flange (D), and pull away from enclosure.

Then, remove inner panel (E):

4. Loosen nut (F) until it clears t-slot (H) in inner panel.
5. Grasp inner panel at two cutouts (G—left and right). Tilt inner panel as shown, passing nut through t-slot.
6. Lower inner panel until tabs (J) clear upper panel, and pull away from enclosure.

Lastly, remove service entrance panel (L):

7. Remove screw (K). Lower inner utility service entrance access panel (L) until clear of two retention slots in top flange, and pull away from enclosure.

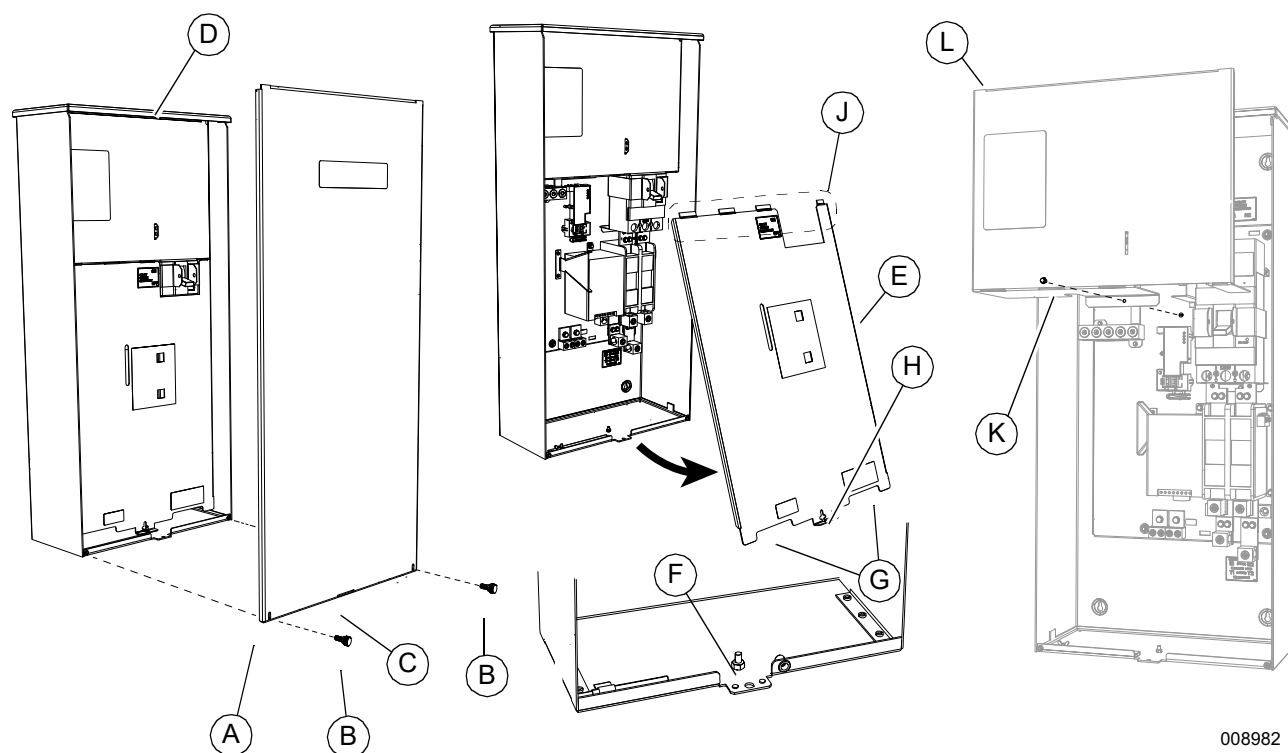

008982

Figure 3-1. Open Enclosure

Connecting Power Source and Generator Power Supply



⚠ DANGER

Electrocution. Turn utility and emergency power supplies to OFF before connecting power source and load lines. Failure to do so will result in death or serious injury. (000116)

Installation and interconnection diagrams are provided in this manual.

NOTE: All installations must comply with national, state, and local codes. It is the responsibility of the installer to perform an installation that will pass the final electrical inspection.

1. Connect utility supply at the utility service disconnect circuit breaker terminals N1 and N2. Follow torque specifications listed on the circuit breaker.
2. See **Figure 3-2**. Connect utility neutral and ground to the upper neutral (A) and ground (B) terminals. Neutral and ground terminals are bonded to each other with a jumper wire (C).

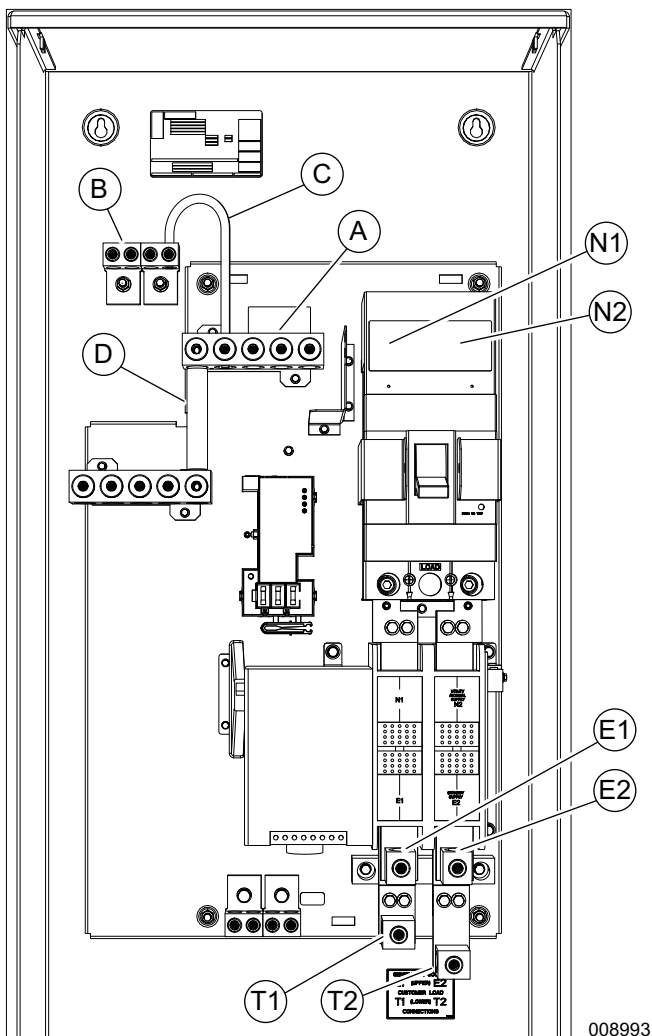

Figure 3-2. Wiring Connections

NOTE: Neutral to ground jumper wire (C) is provided for use if required by local codes.

3. Connect generator to the generator terminals (E1 and E2) on the transfer mechanism.
4. Connect the generator neutral wire to the lower neutral lug.

IMPORTANT NOTE: A jumper wire (D) bonds the upper and lower neutral lugs. **NEVER** remove this wire.

5. Connect a subpanel supply to lower T1 and T2 Terminals. Connect subpanel neutral and ground to lower neutral and ground bars.

Conductor sizes must be adequate to handle the maximum current to which they will be subjected, based on the 75 °C column of tables, charts, etc. used to size conductors. The installation must comply fully with all applicable codes, standards, and regulations.

Knockouts into the transfer switch can be made in the field as needed for entry of power cables and conduit. Conduit entry shall maintain the proper wire bending spaces required by CSA C22.1. A barrier provides separation between the utility and generator supply conductors inside the enclosure.

NOTE: The upper panel has a provision for a utility lock or tag after installation is complete. The service entrance circuit breaker also has a provision for a locking device.

NOTE: If aluminum conductors are used, apply corrosion inhibitor to conductors. After tightening terminal lugs, carefully wipe away any excess corrosion inhibitor.

Tighten terminal lugs to the torque values as noted on the decal located on the inside of the door. After tightening terminal lugs, carefully wipe away any excess corrosion inhibitor.

⚠ CAUTION

Equipment damage. Verify all conductors are tightened to the factory specified torque value. Failure to do so could result in damage to the switch base.

(000120)

Connecting Start Circuit Wires

See **Figure 3-3**. Control system interconnections consist of N1, N2, and T1, and leads 23, 0, and 194. The generator control wiring is a Class 1 signaling circuit. Reference instruction manual of specific engine generator for wiring connection details. Screw heads are straight bladed and cross-bladed, and should be tightened to 3.5 **in-lb** (0.4 Nm).

Recommended wire gauge sizes depend on wire length as specified in the following chart: Consult factory if you are operating more than one transfer switch and SACM.

Recommended Wire Size	Maximum Wire Length
	(One transfer switch and load shed module)
No. 18 AWG	1–115 ft (0.3–35 m)
No. 16 AWG	116–185 ft (36–56 m)
No. 14 AWG	186–295 ft (57–89 m)
No. 12 AWG	296–460 ft (90–140 m)

Exception: Conductors of AC and DC circuits, rated 1000 volts nominal, or less, shall be permitted to occupy the same equipment, cable, or conduit. All conductors shall have an insulation rating equal to at least the maximum circuit voltage applied to any conductor within the equipment, cable, or conduit. See NEC 300.3(C)(1).

Connecting SACM

See **Figure 3-3**. The SACM can control an air conditioner (24 VAC) directly.

Control of Air Conditioner Load

1. Route the thermostat cable (from the furnace/thermostat to the outdoor air conditioner unit) to the transfer switch.
2. Connect the wire to the terminal strip terminals (A/C 1) on the SACM as shown in **Figure 3-3**. These are normally closed contacts which open upon load shed conditions. Route thermostat wire away from high voltage wires.
3. If required, connect additional air conditioners to the terminal strip terminals (A/C 2-4).

Contact Ratings	
A/C 1-4	24 VAC, 1.0 Amp max

NOTE: These instructions are for a typical air conditioner installation. Control of certain heat pumps and 2-stage air conditioners may require special connections or the use of SMMs to control the loads.

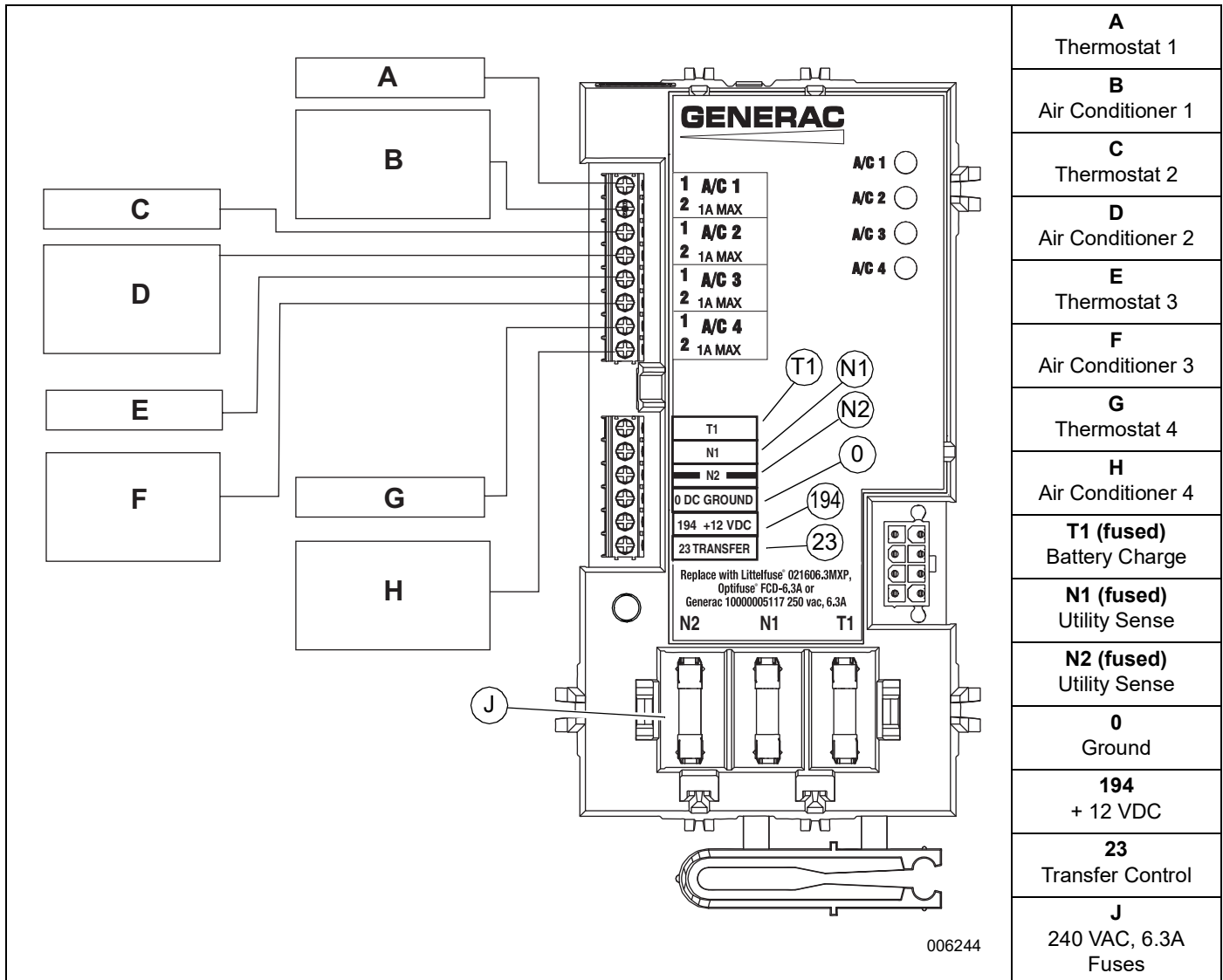

Figure 3-3. Typical SACM Connections

Auxiliary Contacts

CAUTION

Equipment damage. Exceeding rated voltage and current will damage the auxiliary contacts. Verify that voltage and current are within specification before energizing this equipment. (000134a)

See **Figure 3-4**. Auxiliary contacts on the transfer switch are available to operate customer accessories, remote advisory lights, or remote annunciator devices. A suitable power source must be connected to the common terminal (D). Auxiliary contact (A) is optional.

A	Auxiliary Contact (Actuated)
B	Auxiliary Contact (Non-Actuated)
C	Single Contact (Utility Position)
D	Common Terminal
E	Normally Open Terminal
F	Normally Closed Terminal

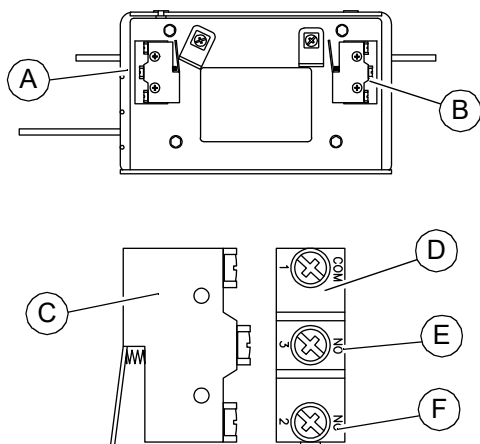

000140

Figure 3-4. Auxiliary Contacts

Auxiliary contact (B) operation is shown in the following chart:

	Switch Position	
	Utility	Standby
Common to Normally Open	Open	Closed
Common to Normally Closed	Closed	Open

NOTE: Auxiliary Contacts are rated 10 amps at 125 or 250 volts AC.

Fault Current Label

See **Figure 3-5**. A Fault Current Identification Label is provided in the bag containing the unit Owner's Manual and transfer switch manual operating handle. The 2017 NEC requires that the short-circuit current rating of the transfer equipment, based on the type of overcurrent protective device protecting the transfer equipment, be field marked on the exterior of the transfer equipment. For NEC compliance, verify the required short-circuit current rating of the transfer switch before installation. The completed label provides the local AHJ (Authority Having Jurisdiction) with the information he or she may require during inspection.

Apply the label to the exterior of the transfer switch enclosure. Use a pen to fill in the required information, and then cover the label with the clear protective decal.

FAULT CURRENT RATING _____

AVAILABLE FAULT CURRENT _____

DATE _____

004496

Figure 3-5. Fault Current Label

This page intentionally left blank.

Section 4: Operation

Functional Tests and Adjustments



Equipment damage. Perform functional tests in the exact order they are presented in the manual. Failure to do so could result in equipment damage.

(000121)

Following transfer switch installation and interconnection, inspect the entire installation carefully. A competent, qualified electrician should inspect it. The installation should comply strictly with all applicable codes, standards, and regulations. When absolutely certain the installation is proper and correct, complete a functional test of the system.

NOTE: Before proceeding with functional tests, read and verify all instructions and information in this section is understood. Also read the information and instructions of labels and decals affixed to the switch. Note any options or accessories that might be installed and review their operation.

Manual Operation



Electrocution. Do not manually transfer under load. Disconnect transfer switch from all power sources prior to manual transfer. Failure to do so will result in death or serious injury, and equipment damage.

(000132)



Equipment damage. Do not use excessive force while manually operating the transfer switch. Doing so could result in equipment damage.

(000122)

See **Figure 4-1**. A manual handle (A) is shipped with the transfer switch. Manual operation must be checked **BEFORE** the transfer switch is operated electrically.

Proceed as follows to check manual operation:

1. Verify generator is OFF.
2. Turn OFF (OPEN) both utility and emergency power supplies to the transfer switch, with whatever means provided (such as the main line circuit breakers).

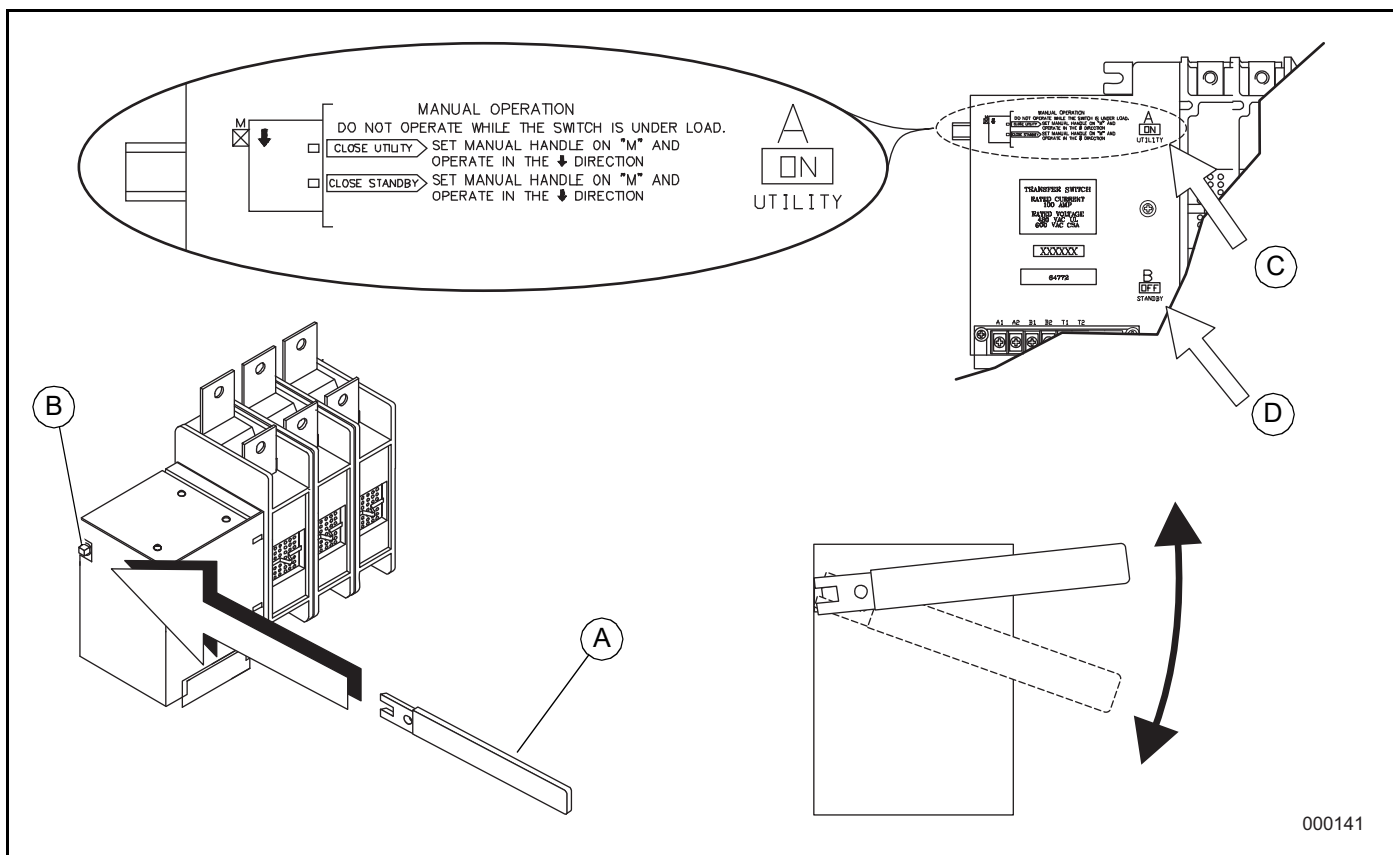

Figure 4-1. Actuating Transfer Switch

3. See **Figure 4-1**. Note position of transfer mechanism main contacts (C, D) by observing display windows in “A” and “B” as follows:
 - Window “A” ON, Window “B” OFF—LOAD terminals (T1, T2) are connected to utility terminals (N1, N2).
 - Window “A” OFF, Window “B” ON—LOAD terminals (T1, T2) are connected to emergency terminals (E1, E2).

Close to Normal Source Side

See **Figure 4-1**. Before proceeding, verify the position of the switch by observing Window “A.” If Window “A” reads “ON”, the contacts are closed in the normal position; no further action is required. If it reads “OFF,” proceed as follows:

- Attach handle (A) to actuating shaft (B). Move handle in the direction of the arrow on the switch cover until it stops—DO NOT FORCE. Release handle slowly to allow the spring in the switch box to relax. “ON” now appears in Window “A” and “OFF” appears in Window “B”.

Close to Standby Source Side

See **Figure 4-1**. Before proceeding, verify the position of the switch by observing Window “B.” If Window “B” reads “ON”, the contacts are closed in the EMERGENCY (STANDBY) position; no further action is required. If it reads “OFF,” proceed as follows:

- Attach handle (A) to actuating shaft (B). Move the handle in the direction of the arrow on the switch cover until it stops—DO NOT FORCE. Release handle slowly to allow the spring in the switch box to relax. “OFF” now appears in Window “A” and “ON” appears in Window “B.”

Return to Normal Source Side

Manually actuate switch to return Window “A” to the “ON” position.

Voltage Checks



⚠ DANGER

Electrocution. High voltage is present at transfer switch and terminals. Contact with live terminals will result in death or serious injury.

(000129)

NOTE: Use the Digital Multimeter (DMM) LowZ low input impedance setting to collect accurate voltage measurements. LowZ eliminates the possibility of inaccurate ghost voltage readings, also known as phantom voltage or stray voltage readings. See DMM manufacturer’s literature for additional information.

Utility Voltage Checks

1. Turn ON the UTILITY power supply to the transfer switch with whatever means provided (such as the UTILITY main line circuit breaker).
2. With an accurate AC voltmeter, check for correct voltage. Measure across ATS terminal lugs N1 and N2; N1 to NEUTRAL and N2 to NEUTRAL.

Generator Voltage Checks



⚠ DANGER

Electrocution. High voltage is present at transfer switch and terminals. Contact with live terminals will result in death or serious injury.

(000129)

1. On the generator panel, select MANUAL mode. The generator will crank and start.
2. Allow generator to stabilize and warm up at no-load for at least five minutes.
3. Set generator main circuit breaker (CB1) to ON (CLOSED).
4. With an accurate AC voltmeter and frequency meter, check the no-load, voltage and frequency. Measure across ATS terminal lugs E1 to E2; E1 to NEUTRAL and E2 to NEUTRAL.

Frequency	60–62 Hz
Terminals E1 to E2	240–246 VAC
Terminals E1 to NEUTRAL	120–123 VAC
Terminals E2 to NEUTRAL	120–123 VAC

5. When certain that generator supply voltage is correct and compatible with transfer switch ratings, turn OFF generator supply to the transfer switch.
6. Set generator main circuit breaker (CB1) to OFF (OPEN).
7. On the generator panel, select OFF to shut down the generator.

NOTE: Do NOT proceed until generator AC output voltage and frequency are correct and within stated limits. If the no-load voltage is correct but no-load frequency is incorrect, the engine governed speed may require adjustment. If no-load frequency is correct but voltage is not, the voltage regulator may require adjustment.

Generator Tests Under Load

1. Set the generator main circuit breaker to OFF (OPEN).
2. Set the utility service disconnect circuit breaker of the transfer switch to OFF (OPEN), and turn OFF (OPEN) all load circuit breakers.

3. Manually actuate the transfer switch main contacts to the emergency (standby) position. See [Manual Operation](#).
4. Select MANUAL mode to start generator. Allow engine to stabilize for a few minutes, and close lid (if applicable).
5. Set the generator main circuit breaker to ON (CLOSED). The generator now powers all LOAD circuits. Check generator operation under load as follows:
 - Turn on electrical loads to the full rated wattage/ amperage capacity of the generator. DO NOT OVERLOAD.
 - With maximum rated load applied, check voltage and frequency across transfer switch terminals E1 and E2. Voltage should be greater than 230 VAC (240 VAC system); frequency should be greater than 59 Hz.
 - Verify gas pressure remains within acceptable parameters (see the generator installation manual).
 - Allow the generator to run under rated load for at least 30 minutes. Observe for unusual noises, vibration, or overheating that might indicate a problem.
6. Set generator main circuit breaker to OFF (OPEN) when checkout under load is complete.
7. Allow generator to run at no-load for several minutes. Then shut down by selecting OFF.
8. Move main switch contacts to utility position.

NOTE: See [Manual Operation](#). Handle and operating lever of transfer switch should be DOWN.

9. Set transfer switch utility service disconnect circuit breaker to ON (CLOSED).

The system is now set for fully automatic operation.

Checking Automatic Operation

Proceed as follows to check system for proper automatic operation:

1. Verify generator is OFF.
2. Set transfer switch utility service disconnect circuit breaker to OFF (OPEN).
3. Verify switch is de-energized.
4. Install front cover of the transfer switch.
5. Set transfer switch utility service disconnect circuit breaker to ON (CLOSED).
6. Set generator main circuit breaker to ON.
7. Select AUTO on generator panel. The system is now ready for automatic operation.
8. Set transfer switch utility service disconnect circuit breaker to OFF (OPEN).

With the generator ready for automatic operation, the engine will crank and start when the utility source power is turned OFF after a five second delay (factory default setting). After starting, the transfer switch will connect load circuits to the standby side after a five second warm-up delay. Allow system to operate through its entire automatic sequence of operation.

NOTE: Timer durations may differ between generators and settings.

With the generator running and loads powered by generator AC output, set the transfer switch utility service disconnect circuit breaker to ON (CLOSED). The following will occur:

- The switch will transfer loads back to the utility power source after approximately 15 seconds.
- The generator will shut down approximately one minute after transfer.

With the generator in the AUTOMATIC mode, the system is now set for fully automatic operation.

Installation Summary

1. Verify the installation has been properly performed as outlined by the manufacturer and that it meets all applicable laws and codes.
2. Verify proper operation of the system as outlined in the appropriate installation and owner's manuals.
3. Educate the end user on proper operation, maintenance, and service call procedures.

NOTE: The utility power circuit breaker in the transfer switch must be turned OFF to simulate a utility outage. Shutting off the main disconnect in a subpanel connected to the transfer switch will NOT simulate an outage.

Shutting Generator Down While Under Load

IMPORTANT NOTE: To avoid equipment damage, follow these steps, in order, when shutting the generator down during utility outages. Shutdowns may be required during outages to perform routine maintenance or to conserve fuel.

To turn the generator OFF (while running in AUTO and online):

1. Turn the main utility disconnect off.
2. Turn the generator MLCB (generator disconnect) to OFF (OPEN).
3. Run the generator for approximately one minute for proper cooling.
4. Turn the generator OFF.

To turn the generator back ON:

1. Put the generator into AUTO. Start generator and warm-up for a few minutes.
2. Set the MLCB (generator disconnect) to ON (CLOSED).

The system now operates in automatic mode. The main utility disconnect can be turned ON (CLOSED). To shut the unit off, repeat this complete process.

Shutting Generator Down To Perform Maintenance

1. Turn the main utility disconnect OFF (OPEN).
2. Turn the MLCB (generator disconnect) on the generator to OFF (OPEN).
3. Press OFF mode on the controller and follow maintenance procedure(s).

To turn the generator back ON:

1. Turn the main utility disconnect ON (CLOSED).
2. Set the MLCB (generator disconnect) on the generator to ON (CLOSED).
3. Put the generator into AUTO mode.

The system is now in automatic mode.

Testing The SACM

See [Figure 4-2](#). A “Test” pushbutton (A) is provided on top of the SACM to test the operation of the load shed functions. The test pushbutton will work when the ATS is in the utility or the generator position.

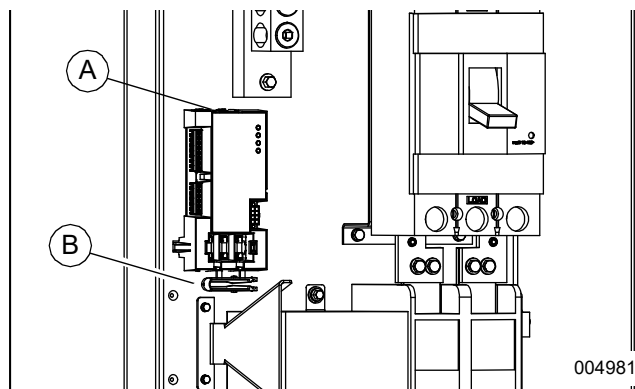

Figure 4-2. Test Pushbutton and Fuse Removal/Installation Tool

1. Turn on the utility supply to the ATS.
2. Verify managed loads are powered and all LEDs illuminate on SACM.
3. Press the TEST button on the SACM.
4. Verify that all of the connected loads to be “shed” become disabled.
5. After five minutes, verify A/C 1 is energized and Status LED A/C 1 is ON.
6. After another 15 seconds, verify A/C 2 is energized and Status LED A/C 2 is ON.
7. After another 15 seconds, verify Load A/C 3 is energized and Status LED Load A/C 3 is ON.
8. After another 15 seconds, verify A/C 4 is energized and Status LED A/C 4 is ON.

SACM Fuse Service

See [Figure 4-2](#). A fuse removal and installation tool (B) is included in the SACM housing.

If a fuse requires replacement, snap the tool free with an appropriate tool such as diagonal pliers, and use it to replace the fuse. The tool can be stored in the SACM housing retainer directly above the fuses, with the large thumb tab facing out.

Use only Generac replacement fuses—part number 10000005117, rated 240 VAC, 6.3 Amps, 10,000 AIC.

Alternative fuses are Littelfuse® 021606.3MXHP or Optifuse® FCD-6.3.

Testing The SMM

Refer to the SMM Owner’s or Installation Manual for testing procedure.

Section 5: Drawings and Diagrams

Installation Drawing—400A Service Entrance Rated

No. 0K2438-A

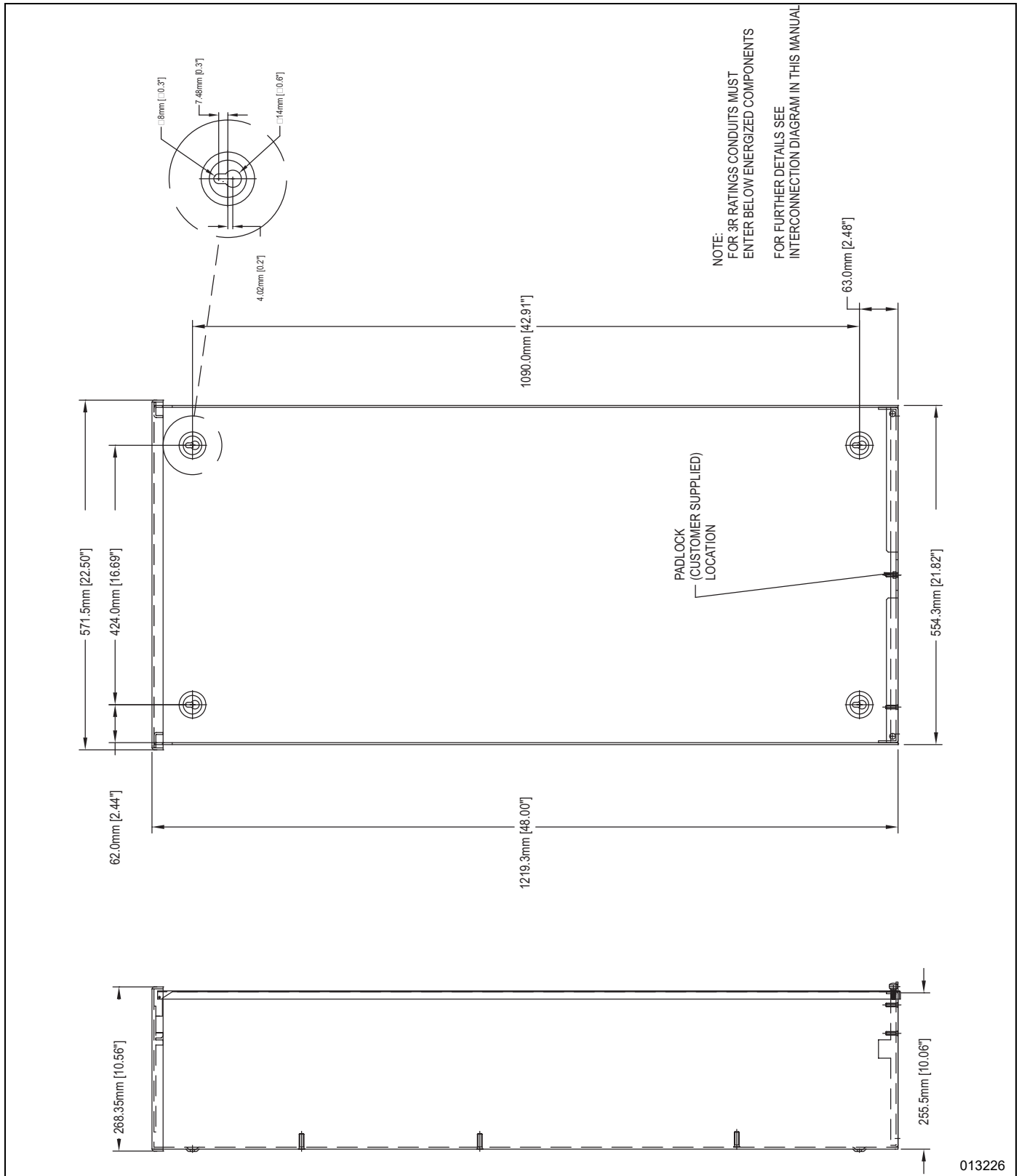

Interconnection Drawing—Liquid Cooled Generator

No. 1000041110 (Part 1 of 2)

GROUP G

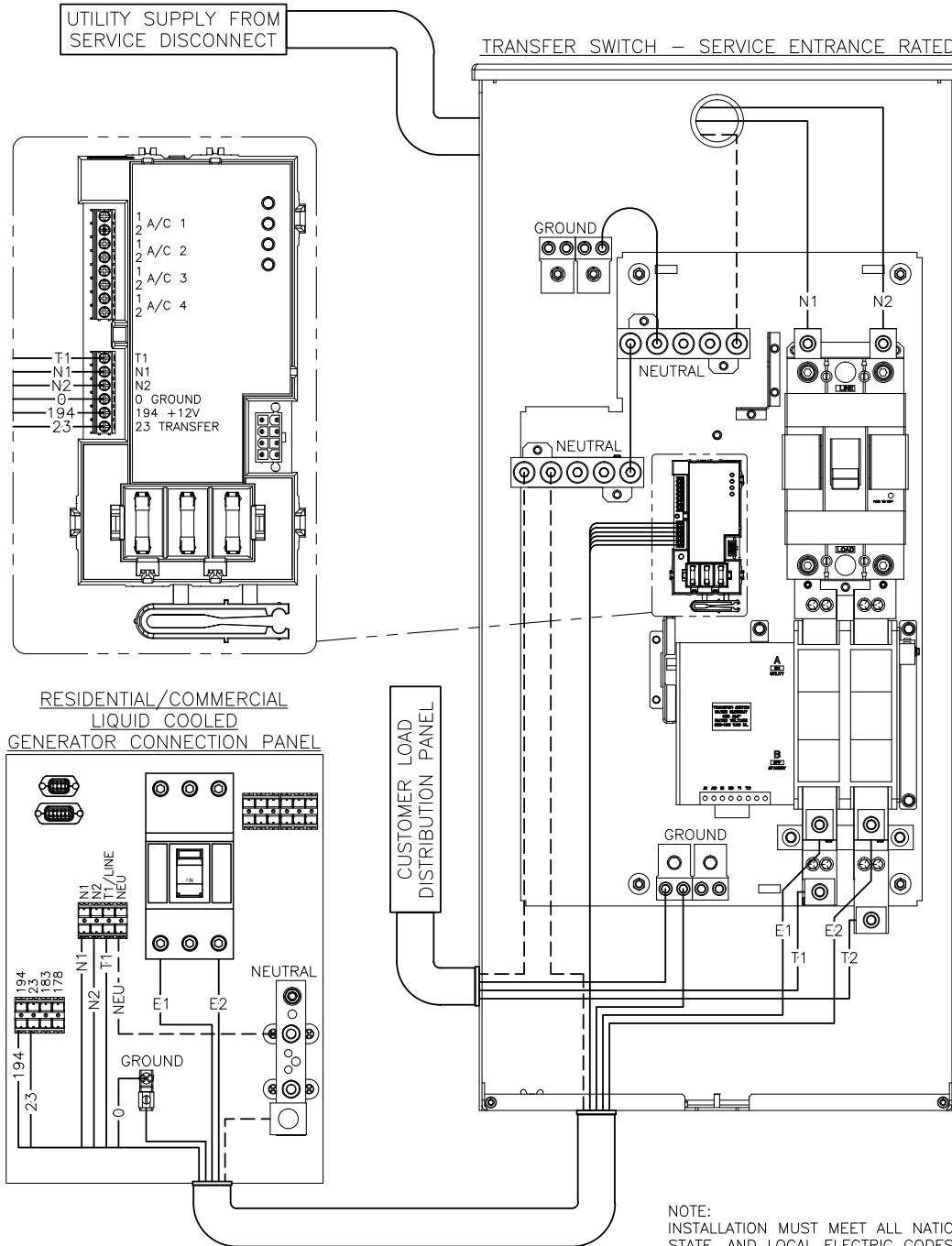

NOTE:
INSTALLATION MUST MEET ALL NATIONAL,
STATE, AND LOCAL ELECTRIC CODES.

REVISION: A
DATE: 07/18/18

INTERCONNECTION DIAGRAM
ID 400A CUL SACM
DRAWING #: 1000041110

013227

Interconnection Drawing—Liquid Cooled Generator

No. 1000041110 (Part 2 of 2)

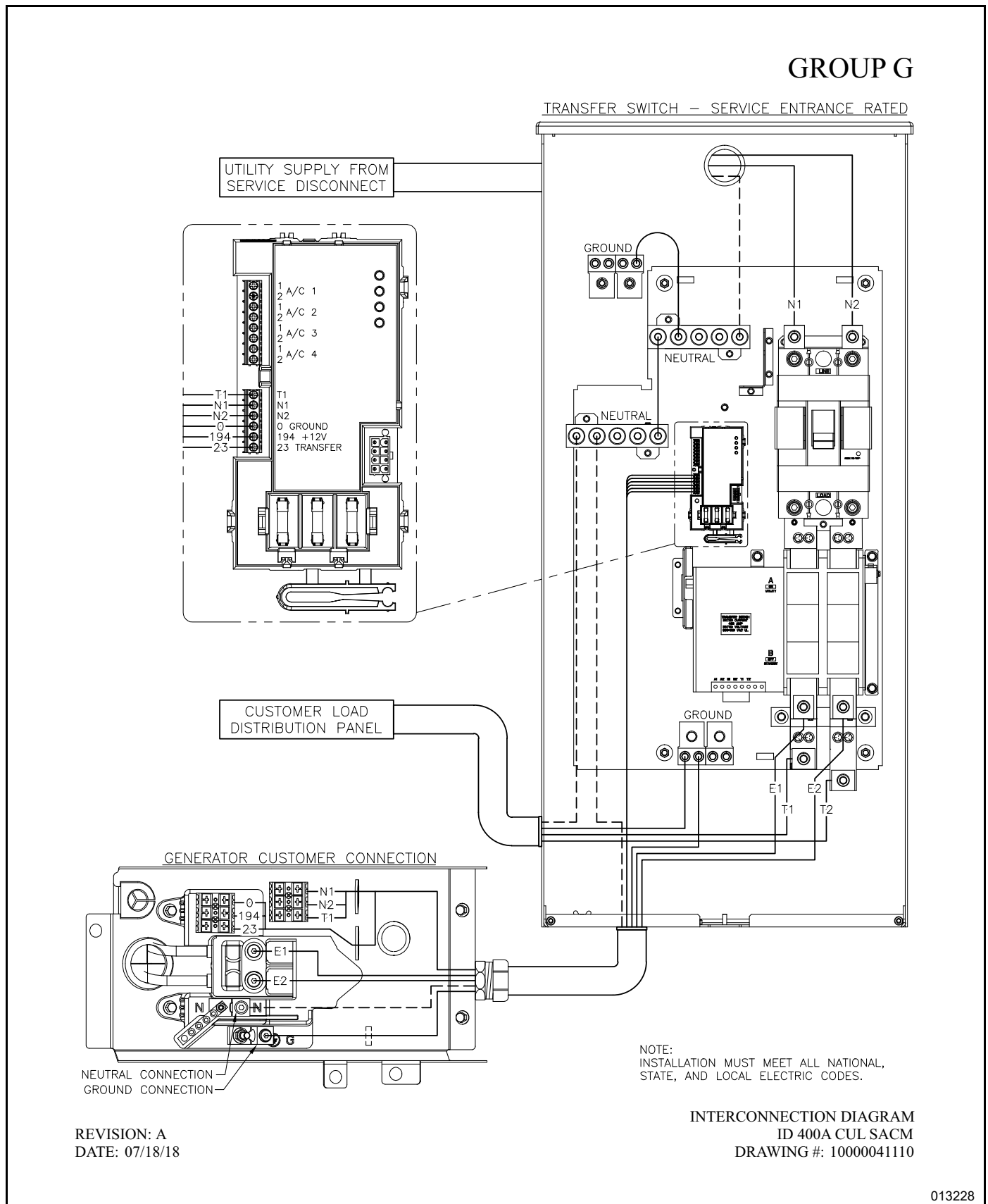

REVISION: A
DATE: 07/18/18

013228

Schematic Diagram

No. 1000041100 (Part 1 of 2)

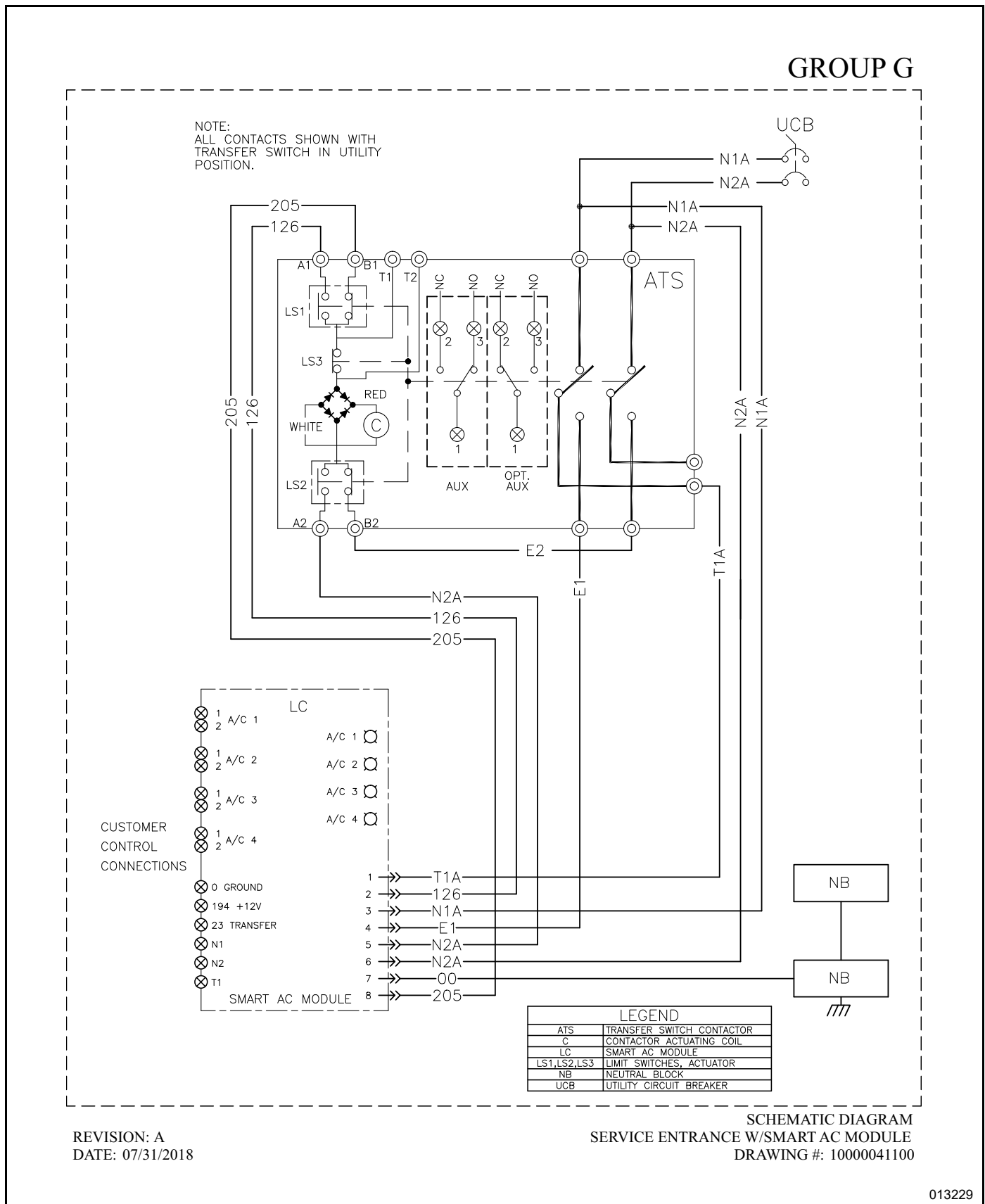

Wiring Diagram

No. 1000041100 (Part 2 of 2)

GROUP G

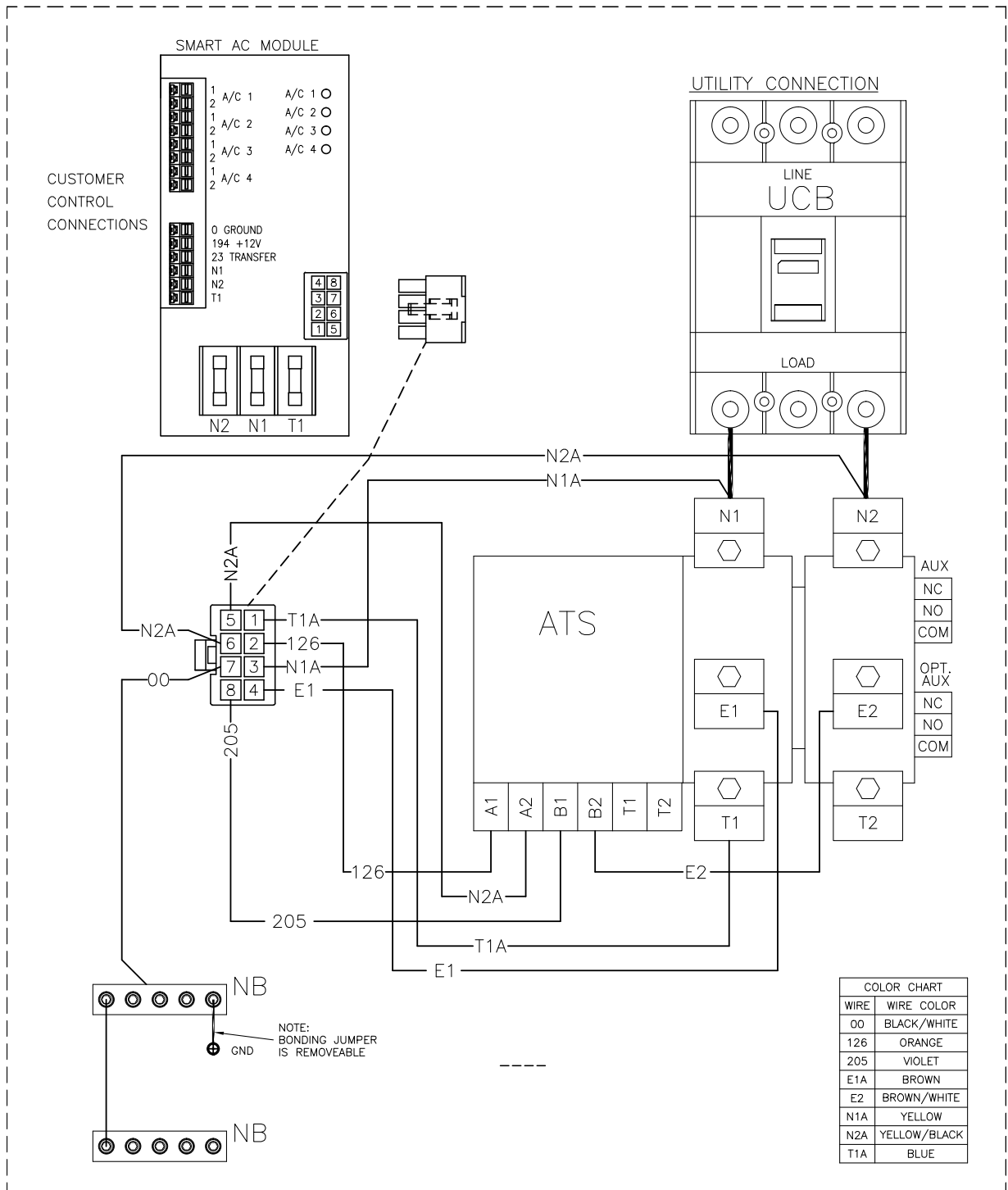

REVISION: A
DATE: 07/31/2018

WIRING DIAGRAM
SERVICE ENTRANCE W/SMART AC MODULE
DRAWING #: 1000041100

013230

This page intentionally left blank.

Part No. 10000041019 Rev. B 10/07/2021

©2021 Generac Power Systems, Inc.

All rights reserved.

Specifications are subject to change without notice.

No reproduction allowed in any form without prior
written consent from Generac Power Systems, Inc.

GENERAC®

Generac Power Systems, Inc.
S45 W29290 Hwy. 59
Waukesha, WI 53189
1-888-GENERAC (1-888-436-3722)
www.generac.com